

# ActivePure®

BEYOND GUARDIAN

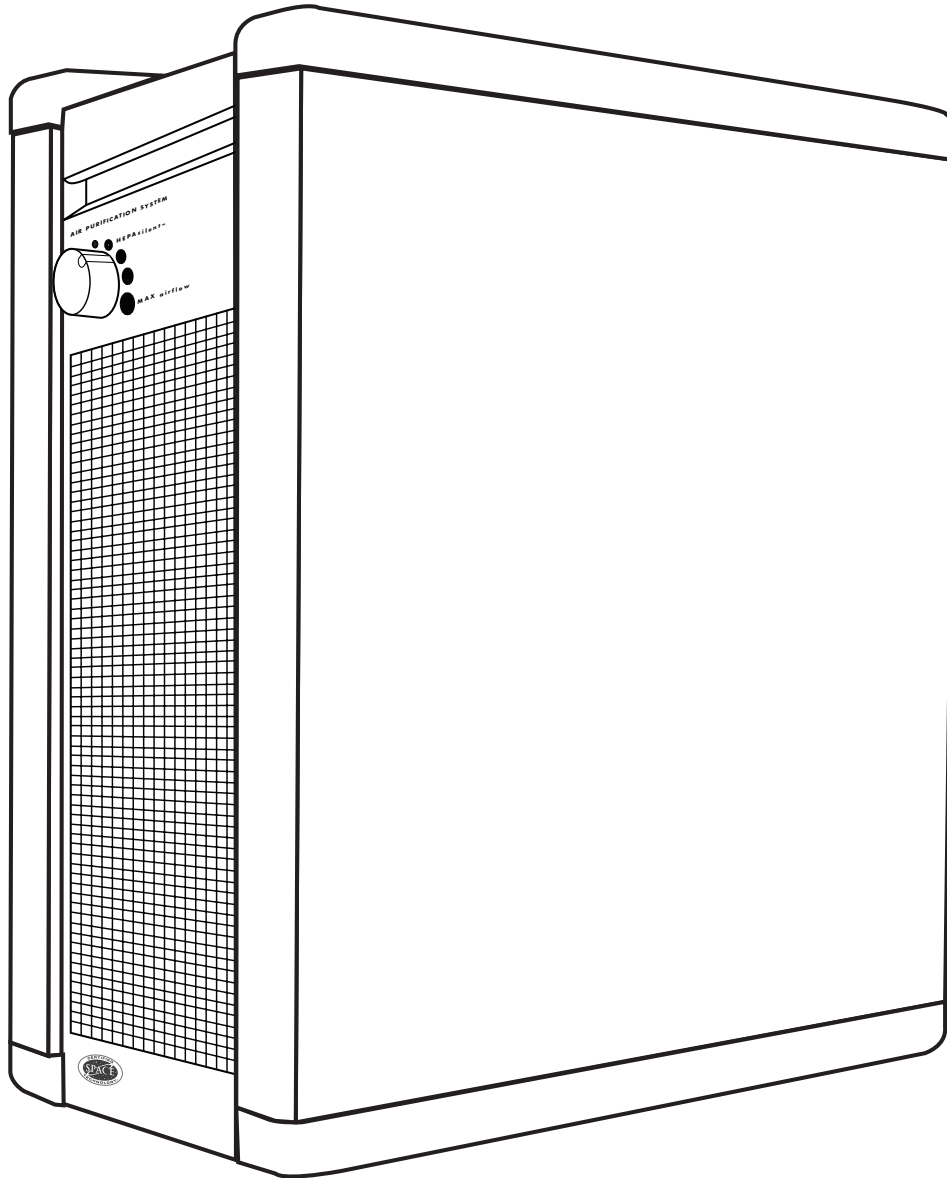

MODEL: F159J

## AIR PURIFICATION SYSTEM

READ MANUAL CAREFULLY FOR  
PROPER USE AND OPTIMAL OPERATION.



# GENERAL INFORMATION

## PRODUCT OVERVIEW

Congratulations on your purchase! Your new ActivePure® Beyond Guardian utilizes tested ActivePure Technology to provide 24/7 surface and air purification and is designed to provide years of trouble-free, low maintenance operation. Be sure to read and follow all service procedures outlined in this owner's manual, and use only genuine ActivePure replacement parts.

## CONTENTS

Product Overview . . . . .	2
Specifications. . . . .	2
Storage and Disposal . . . . .	2
Important Safety Instructions . . . . .	3
For Canadian Customers Only . . . . .	4
Product Features . . . . .	5
Operation. . . . .	5
Settings. . . . .	6
Maintenance . . . . .	6
Filters. . . . .	7
ActivePure® Cell Assembly. . . . .	7
Changing the Filters. . . . .	7
Replacing the ActivePure Cell Assembly . . . . .	8
Replacement Parts & Service . . . . .	9
Warranty Information . . . . .	10
FCC Declaration & Responsible Party . . . . .	11

## STORAGE AND DISPOSAL

Do not dispose of this product as household waste. Electrical waste and electronic products should be appropriately recycled as required by practices established by your local authority.



## SPECIFICATIONS

### ActivePure® Beyond Guardian

- Model Number: F159J
- Sales Number: 00764

Meets California ozone emissions limit. CARB Certified

### Technology:

- ActivePure® Technology
- HEPA Filtration
- Activated Carbon
- Carbon Brushes

### Electrical:

- Input Voltage: 120 VAC; 60Hz
- Power Consumption: 23 to 80 watts

### Mechanical:

- Motor 230 VAC; 0.28 A
- Air Exchange: 4.2 changes per hour (351 / sq. ft.)

### Safety:

- Complies to UL 867

### Airflow Rate:

• Speed 1:	75 CFM	130 m <sup>3</sup> /h
• Speed 2:	95 CFM	160 m <sup>3</sup> /h
• Speed 3:	150 CFM	250 m <sup>3</sup> /h
• Speed 4:	240 CFM	410 m <sup>3</sup> /h

### Sound Level:

• Speed 1:	32 dB(A)
• Speed 2:	39 dB(A)
• Speed 3:	46 dB(A)
• Speed 4:	58 dB(A)

### Weight & Dimensions:

- 34 lbs (15.5 kg)
- 23" H x 20" W x 11" D (590 mm H x 500 mm W x 275 mm D)

### Operating Temperature:

- (Return Air) 30 °F to 95 °F (-1 °C – -35 °C)

### Coverage:

- For Commercial Use: Every facility is unique and proper configuration is as important as the technology. To validate coverage in your facility, speak to your sales representative or call customer service at 800-572-1446.

### Warranty:

- Limited three (3) year warranty

We reserve the right to change or modify any specification without notice.

If you have any questions concerning this, or any ActivePure® product, contact ActivePure® Customer Service at 800.572.1446 or email customerservice@ActivePure.com.

# IMPORTANT SAFETY INSTRUCTIONS



- When using an electrical appliance, basic precautions should always be taken
- To reduce the risk of electrical shock, this appliance has a grounded plug (with a third prong); this plug will fit in a grounded outlet only one way; if it does not fit, contact a qualified electrician to install the proper outlet; **DO NOT** change the plug in any way; **DO NOT** use adapters
- To reduce risk of fire, electrical shock, or injury to persons, observe the following:

Read this manual in its entirety before using your ActivePure® Beyond Guardian.

## Keep out of the reach of children.

- Use only as described in this manual
- This unit contains a UVC bulb
- Unintended use of the unit or damage to the housing may result in the escape of dangerous UVC radiation. UVC radiation may cause eye and skin irritation. Avoid exposing eyes and skin to ultraviolet radiation.
- **DO NOT** attempt to repair or adjust any of the electrical or mechanical functions of the Beyond Guardian Air. Contact ActivePure® Customer Service for service information
- Unit will automatically turn off when the front door is open for cleaning and filter replacement; Read the maintenance instructions before opening the front door
- **DO NOT** use filters other than authorized Guardian Air filters
- **DO NOT** use outdoors or on wet surfaces
- **DO NOT** look directly at the UV light inside unit when operating. Eye damage may occur
- **DO NOT** allow to be used as a toy; Keep out of reach from children; close attention is necessary if operated near children
- **DO NOT** use with damaged cord or plug. If unit is not working as it should, has been dropped, damaged, left outdoors, or dropped into water, **DO NOT** use, and return it to a service center
- **DO NOT** pull or carry by cord, use cord as a handle, close door on cord, or pull cord around sharp edges or corners. Keep cord away from heated surfaces
- **DO NOT** unplug by pulling on cord. To unplug, grasp the plug, not the cord
- **DO NOT** handle plug or unit with wet hands
- **DO NOT** allow foreign objects to enter the ventilation or exhaust openings
- Keep hair, loose clothing, fingers, and all parts of body away from openings and moving parts
- Turn off all controls before unplugging
- To avoid electric shock and fire hazards, plug directly into an appropriate electrical outlet (see voltage on unit) using cable provided (beneath unit)
- To reduce the risk of electrical shock, this unit has a grounded plug (with a third prong); This plug will fit in a grounded outlet only one way. If it does not fit, contact a qualified electrician to install the proper outlet. **DO NOT** change the plug in any way. **DO NOT** use adapters
- The unit should not be used near the presence of oxygen tanks or other flammable gasses
- Place the unit in a location away from the wall that allows air to move freely into, around and out of the unit

**SAVE THESE INSTRUCTIONS**

# FOR CANADIAN CUSTOMERS ONLY

---

## ACTIVEPURE® BEYOND GUARDIAN

Sales No. : 00764

This UV device helps reduce the spread of viruses in the air.

**Keep out of the reach of children**

**Please read the label and owner's manual before using:** [activepure.com/manuals](http://activepure.com/manuals)

### **PRECAUTIONS:**

**WARNING:** UV radiation emitted from this device. Unintended use of the device, or damage to the housing, may result in exposure to ultraviolet radiation. Ultraviolet radiation may cause eye and skin irritation. Avoid exposing eyes and skin to ultraviolet radiation.

**FIRST AID INSTRUCTIONS:** Please contact your healthcare provider in the event of injury caused by this device.

### **DIRECTIONS FOR USE:**

Plug the cord into a working electrical outlet, leaving at least 6 inches of open area to allow for airflow. Please see this manual for detailed instructions on using, handling, storing and disposing of the device, and procedures to mitigate any associated risks.

The use of this device is a supplement to and not a substitute for standard infection control practices; users must continue to follow all current infection control practices, including those related to the cleaning and disinfection of environmental surfaces.

### **FOR INQUIRIES CONTACT:**

AERUS CANADA, INC.  
Laird Business Park  
3480 Laird Road, Units 2-5  
Mississauga, Ontario, Canada, L5L 5Y4

W. Parrell, Manager  
(905) 569-9399  
[wparrell@aerusonline.com](mailto:wparrell@aerusonline.com)

Aerus Canada, Inc. is affiliated with ActivePure Manufacturing, LLC  
1300 Valley Drive, Bristol, Virginia 24201

# PRODUCT FEATURES

It is important to be familiar with the parts of the ActivePure Beyond Guardian. If any parts are missing, contact your sales representative or ActivePure® Customer Service.

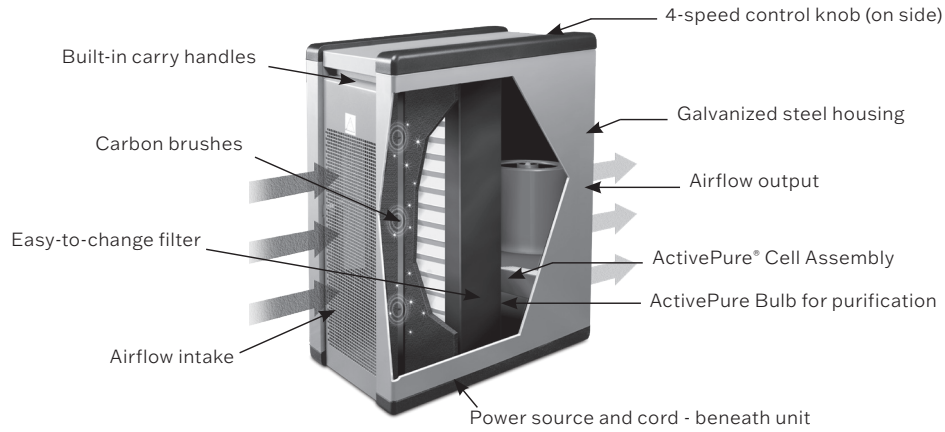

## TEN UNIQUE TECHNOLOGIES

1. Directional air intake for less resistance
2. Multiple carbon brushes aid in the capture of contaminants
3. Carbon layer prefilters large particles and odors
4. Water-proof, polypropylene filter captures small particles
5. ActivePure Bulb is a germicidal bulb
6. Our proprietary ActivePure Technology reduces surface and airborne contaminants
7. 4-speed dual intake fan moves particles toward filter
8. Angled blades at emission point create dynamic air flow through room
9. Whisper quiet HEPASilent™ setting on 4-speed control knob
10. Durable all-steel construction for durability & sound-insulation

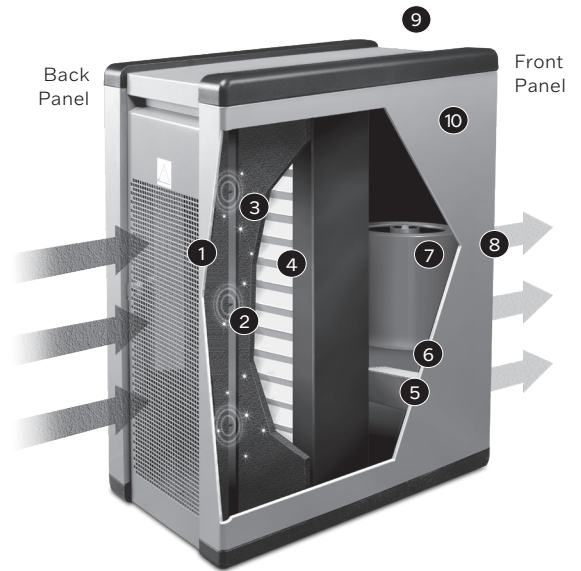

## OPERATION



### DO NOT place the unit:

- Directly on or near soft furnishing (such as bedding or curtains)
- Near electronically sensitive device such as a computer (within 6 in / 10 in)
- Near sources of heat (such as radiators, fireplaces or ovens)
- Near oxygen tanks or other combustible gases
- Near water, outdoors or in a damp or wet areas (such as bathrooms)

## OPERATION (CONTINUED)

---

1. Take your ActivePure® Beyond Guardian unit out of the shipping carton and remove all protective materials.
2. Place the unit in a location away from the wall that allows air to move freely into, around and out of the unit. The rear of the unit requires 6 inches or more of open area to allow unrestricted airflow.
3. Attach cord to unit, if required. Plug the cord into a working electrical outlet.
4. When turning the unit on, turn the speed control to MAX airflow for a few minutes of fast initial purification.
5. After a few minutes, adjust the control to the desired speed.

**NOTE:** Safety switch automatically turns power off when door is opened.

## SETTINGS

---

When turning the ActivePure Beyond Guardian on, turn the speed control to maximum airflow for a few minutes of fast initial cleaning. Then adjust the control to the desired speed.

There are four settings on the ActivePure Beyond Guardian:

1. HEPASilent™ (low fan speed)
2. Moderate fan speed (for normal use)
3. High fan speed (for a large room)
4. Maximum operation (for fast initial cleaning)

For best results, run your ActivePure Beyond Guardian 24 hours a day, 7 days a week, giving you the benefits of ActivePure Technology day and night.

**NOTE:** Safety switch automatically turns power off when door is opened.

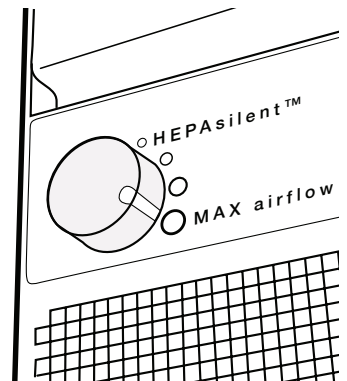

## MAINTENANCE

---

Our air purifiers are designed to help improve indoor air with minimum impact on the environment.

- The ActivePure® HEPA particle filter is made of polypropylene, an eco-friendly plastic; unlike other common filters, our filter contains no aluminum, triclosan or other chemical additives
- All major parts are made from high-quality galvanized steel, not plastic; the steel housing is noise-muffling, providing quiet operation; the external parts have been powder coated for endurance and environmental protection
- The ActivePure Beyond Guardian is energy efficient; from lowest to highest speed, it uses from 23 to 80 watts – no more than a lightbulb
- ActivePure® air purification systems are built for years of use

### KEEP YOUR ACTIVEPURE BEYOND GUARDIAN LOOKING GOOD AND WORKING WELL

The ActivePure Beyond Guardian features award-winning design, materials and workmanship.

Keep your unit in top condition with these cleaning tips:

- Always unplug unit before cleaning
- Wipe the exterior with a soft, clean, damp cloth
- Vacuum the small inlets on each end panel with a soft brush attachment
- Clean inside the ion chamber by opening the front door of the unit and opening the door of the ion chamber (right-hand side)
- Never clean with gasoline, chemical solvents or corrosive materials – they may damage the surface

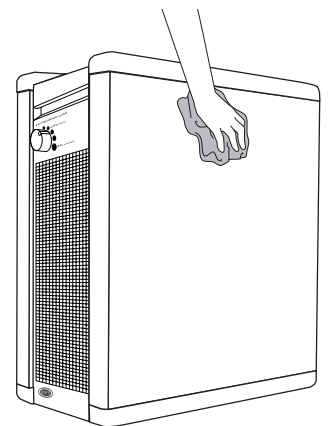

## FILTERS

ActivePure® HEPA technology makes the ActivePure Beyond Guardian incredibly quiet. Units come with one HEPASilent™ particle filter (installed).

The ActivePure® HEPA particle filter is made of polypropylene, which mechanically filters out airborne particles (dust, pollen, pet dander, mold spores and other airborne particles). To maximize filter effectiveness, particles are negatively charged before reaching the filter.

**For optimal performance, ActivePure® recommends that you replace filter at least every 6 - 12 months, depending on usage.**

**NOTE:** Use only ActivePure® HEPA particle filters to ensure proper functioning and to qualify your unit for full warranty coverage.

## ACTIVEPURE® CELL ASSEMBLY

To maintain optimal performance and full warranty benefits, the ActivePure Cell Assembly should be replaced once every 12 months. For questions, call for further assistance at 800.572.1446 or email [customerservice@ActivePure.com](mailto:customerservice@ActivePure.com).

## CHANGING THE FILTERS



Disconnect power before changing filter.

### STEP 1:

Open the front door from the right hand side.

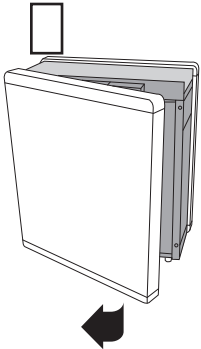

### STEP 2:

Remove old filter.

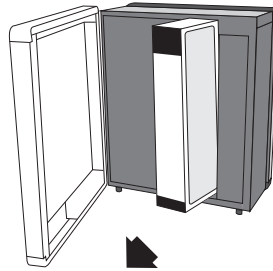

### STEP 3:

Clean filter chamber. (See Page 4)

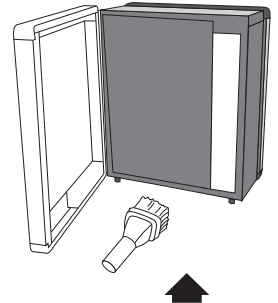

### STEP 4:

Replace with new ActivePure® HEPA particle filter.

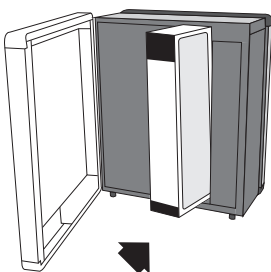

### STEP 5:

Close front door.

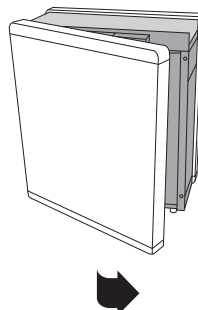

# REPLACING THE ACTIVEPURE CELL ASSEMBLY



**WARNING**

UV Light in operation; disconnect unit from power source before servicing; failure to follow warnings may result in severe eye damage.



**CAUTION**

For optimal performance and to maintain the Limited 5 year warranty, it is required to replace the ActivePure Cell Assembly once every 12 months, even if the ActivePure Bull appears to be operating normally.

- Step 1:** Always disconnect (unplug) unit from electrical power source before replacing the ActivePure® Cell Assembly.
- Step 2:** If necessary, relocate the unit to an appropriate area to perform cell replacement.
- Step 3:** Remove the 4 screws securing the old cell mounting plate on the unit.
- Step 4:** Slide the old ActivePure Cell Assembly out of the unit and disconnect the bulb socket.
- Step 5:** Open the replacement cell carton and remove the new ActivePure Cell Assembly.
- Step 6:** Place old ActivePure Cell Assembly inside the empty new cell carton and dispose of properly.
- Step 7:** Reattach the bulb connection to the new ActivePure Cell Assembly.
- Step 8:** Slide the new ActivePure Cell Assembly back inside the unit and secure with the 4 screws removed in Step 3.
- Step 9:** The ActivePure Beyond Guardian is now ready to be used.

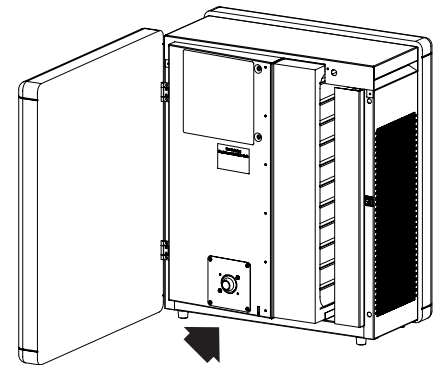
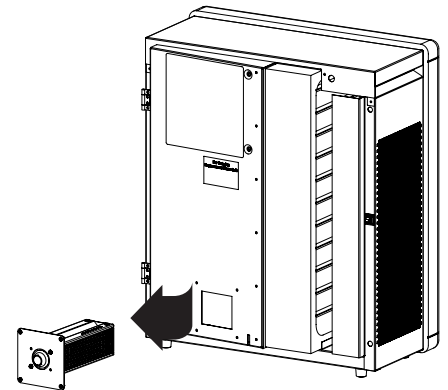

Visit [lamprecycle.org](http://lamprecycle.org) for proper bulb disposal regulations



# REPLACEMENT PARTS & SERVICE



Use only replacement parts recommended by the manufacturer.

REPLACEMENT PARTS	Part Number
ActivePure® HEPA Filter	49949
ActivePure Cell Assembly (ozone free)	50086

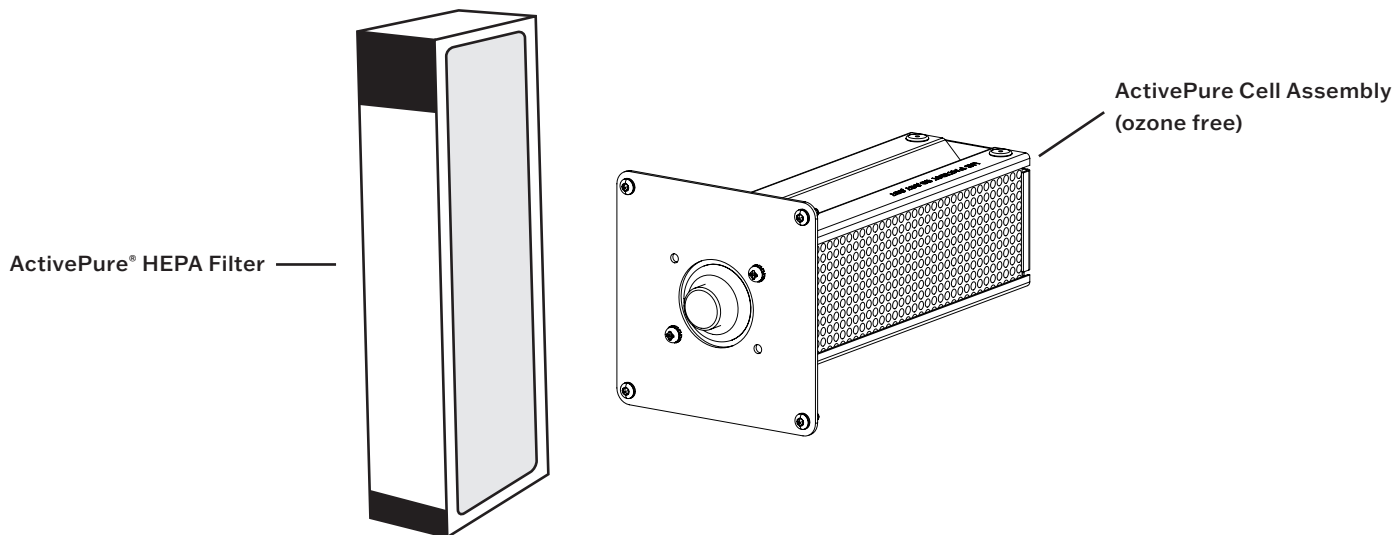

For prompt service, call your ActivePure representative or the nearest ActivePure location. Your authorized ActivePure location offers you the best in service both during and after the warranty period, as well as genuine ActivePure parts and supplies.

Every effort is made to ensure that customers receive an up-to-date instruction manual on the use of ActivePure products; however, from time to time, modifications to our products may without notice make the information contained herein subject to alteration.

**To order replacement parts, contact your sales representative or ActivePure® Customer Service for further assistance at 800.572.1446 or email [customerservice@ActivePure.com](mailto:customerservice@ActivePure.com).**

# WARRANTY INFORMATION

## LIMITED THREE (3) YEAR WARRANTY

To register your ActivePure® Beyond Guardian unit, call Customer Service at 800.572.1446 or email at CustomerService@ActivePure.com.

### WHAT IS COVERED BY THIS WARRANTY

We warrant the ActivePure Beyond Guardian (excluding filters) to the consumer, subject to the conditions below, against defects in workmanship or material, provided that the products are returned to a service location within the following time periods:

- ActivePure Beyond Guardian within three (3) years from date of purchase
- ActivePure Cell Assembly within one (1) year from date of purchase

### MAINTENANCE REQUIREMENTS

This warranty is expressly conditioned upon proper installation, operation, cleaning and maintenance, all in accordance with the Owner's Manual. Failure to meet any of these requirements will void this warranty. Servicing of your ActivePure Beyond Guardian by parties other than our authorized representative and/or using parts other than genuine parts will also void this warranty. This warranty is contingent upon:

- Replacing your HEPA filters with genuine ActivePure filters every 12 months if run 24/7; if run 12 hours or less per day, the filter should be changed every 24 months (proof of change required)
- Replacing the ActivePure Cell Assembly with a genuine ActivePure part once every 12 months (proof of change required)

### HOW TO OBTAIN WARRANTY SERVICE

Customers must contact their ActivePure sales representative or Customer Service and provide proof of purchase within the above time periods. We will repair or replace and return the product, without charge and within a reasonable period of time, subject to the conditions in the above paragraphs, if its examination shall disclose any part to be defective in workmanship or material. If we, in our discretion, are unable to repair the product after a reasonable number of attempts, we will provide either a refund of the purchase price or a replacement unit, at the company's option.

### WHAT IS NOT COVERED BY THIS WARRANTY

This product is intended for household and commercial use. Ordinary wear and tear shall not be considered a defect in workmanship or material. These warranties do not apply for loss or damage caused by accident, fire, abuse, misuse, modification, misapplication, or by any repairs other than those provided by an authorized ActivePure location.

### UNAUTHORIZED CHANNELS & MISSING SERIAL NUMBERS

If a valid serial number is missing from the product, the warranty will be voided. ActivePure products are authorized for sale through ActivePure representatives only. Warranties are voided if a product is purchased through unauthorized channels, this includes websites that are not authorized to use ActivePure trademarked names, images and logos as well as Internet auction sites (e.g. ebay and Craigslist). The only approved Internet presence for ActivePure products is activepure.com. To confirm warranty coverage prior to purchasing a product, contact ActivePure at 800.572.1446 with the serial number located on the back of the unit.

### EXCLUSION OF OTHER WARRANTIES AND CONDITIONS

EXCEPT AS PROVIDED HEREIN, AND TO THE EXTENT CONSISTENT WITH APPLICABLE LAWS, ACTIVEPURE MAKES NO REPRESENTATION OR WARRANTY OF ANY KIND. ALL OTHER WARRANTIES OF ANY KIND, EXPRESS OR IMPLIED, ARE HEREBY EXPRESSLY DISCLAIMED, INCLUDING ANY IMPLIED WARRANTY OF MERCHANTABILITY OR FITNESS FOR A PARTICULAR PURPOSE.

### LIMITATION OF LIABILITY FOR SPECIAL, INCIDENTAL OR CONSEQUENTIAL DAMAGES

TO THE EXTENT CONSISTENT WITH APPLICABLE LAWS, ACTIVEPURE SHALL NOT IN ANY CASE BE LIABLE FOR SPECIAL, INCIDENTAL OR CONSEQUENTIAL DAMAGES ARISING FROM BREACH OF EXPRESS OR IMPLIED WARRANTIES, CONDITIONS, GUARANTEES OR REPRESENTATIONS, BREACH OF CONTRACT, NEGLIGENCE OR ANY OTHER LEGAL THEORY. Such excluded damages include, but are not limited to, loss of profits or revenue and loss of the use of the products.

### FOR U.S. APPLICATION ONLY

This warranty gives you specific legal rights, and you may also have other rights which vary from state to state. Some states do not allow limitations on warranties, or on remedies for breach. In such states, the above limitations may not apply to you.

### FOR CANADIAN APPLICATION ONLY

Exclusion of Subsequent Owners: Except as otherwise required by applicable legislation, this warranty is not transferable. This warranty gives you specific legal rights and you may also have other rights which vary from province to province. Some provinces and territories do not allow limitations on warranties, or on remedies for breach. In such provinces or territories, the above limitations may not apply to you.

If any provision of this warranty or part thereof is held by a court of competent jurisdiction to be invalid, illegal or unenforceable, the validity, legality and enforceability of the remaining provisions or parts thereof will not in any way be affected or impaired within the jurisdiction of that court. This entire warranty shall continue to be valid, legal and enforceable in any jurisdiction where a similar determination has not been made.

This warranty is provided by:  
ActivePure Manufacturing, LLC  
1300 Valley Drive,  
Bristol, VA 24201

### SERVICE

Every effort is made to ensure that customers receive an up-to-date instruction manual on the use of our products; however, from time to time, modifications to our products may without notice make the information contained herein subject to alteration. For the latest information, please call Customer Service at 800.572.1446 or email at CustomerService@ActivePure.com.

# FCC DECLARATION & RESPONSIBLE PARTY

---

This equipment has been tested and found to comply with the limits for a Class B digital device, pursuant of part 15 of the FCC Rules. These limits are designed to provide reasonable protection against harmful interference in a residential installation. This equipment generates, uses, and can radiate radio frequency energy, and if not installed and used in accordance with the instructions, may cause harmful interference to radio communications. However, there is no guarantee that interference will not occur in a particular installation. If this equipment does cause harmful interference to radio or television, which can be determined by turning the equipment off and on, the user is encouraged to try to correct the interference by one or more of the following measures:

- Reorient or relocate the receiving antenna.
- Increase the separation between the equipment and receiver.
- Connect the equipment into an outlet on a circuit different from that to which the receiver is connected.
- Consult the Independent Owner for help.

## FCC DECLARATION OF CONFORMITY

**Name:** ActivePure Beyond Guardian

**Model:** F159J

**Manufacturer:** ActivePure Manufacturing, LLC

**This device complies with Part 15 of the FCC Rules.**

## RESPONSIBLE PARTY

ActivePure Manufacturing, LLC

1300 Valley Drive

Bristol, VA 24201

Ph: 800.572.1446

**Signature:** \_\_\_\_\_



**Printed Name:** Andrew Eide

**Title:** Vice President of Product Development  
and Manufacturing

**Date:** 08/11/2023



For information regarding the use of this product please call Customer Service at  
[800.572.1446](tel:800.572.1446) or email at [customerservice@ActivePure.com](mailto:customerservice@ActivePure.com)

[ActivePure.com](https://ActivePure.com)

ActivePure Manufacturing, LLC | Bristol, VA 24201 | 800.572.1446

© ActivePure Manufacturing. All Rights Reserved.

ABG\_OM\_65-00837\_VA-01647